

SECTION - A**GENERAL APTITUDE**

- Q.1** After playing _____ hours of tennis, I am feeling _____ tired to walk back.
(a) too/too (b) too/two
(c) two/two (d) two/too

Ans. (d)

End of Solution

- Q.2** The average of the monthly salaries of M, N and S is ₹4000. The average of the monthly salaries of N, S and P is ₹5000. The monthly salary of P is ₹6000. What is the monthly salary of M as a percentage of the monthly salary of P?
(a) 50% (b) 75%
(c) 100% (d) 125%

Ans. (a)

$$M + N + S = 4000 \times 3 = ₹12000 \quad \dots (i)$$

$$N + S + P = 5000 \times 3 = ₹15000 \quad \dots (ii)$$

$$\therefore P = ₹6000$$

$$\text{From (ii), } N + S = ₹9000$$

$$\text{From (i), } N + 9000 = 12000$$

$$N = 3000$$

$$\frac{M}{P} = \frac{3}{6} = \frac{1}{2} \approx 50\%$$

End of Solution

- Q.3** A person travelled 80 km in 6 hours. If the person travelled the first part with a uniform speed of 10 kmph and the remaining part with a uniform speed of 18 kmph. What percentage of the total distance is travelled at a uniform speed of 10 kmph?
(a) 28.25 (b) 37.25
(c) 43.75 (d) 50.00

Ans. (c)

Let x distance cover with 10 kmph so, $80 - x$ will be covered with 18 kmph.

\therefore Total time to cover distance is 6 hr.

$$\Rightarrow \left(\frac{x}{10}\right) + \left(\frac{80-x}{18}\right) = 6$$

$$\Rightarrow \left(\frac{9x}{90}\right) + \frac{5(80-x)}{90} = 6$$

$$\Rightarrow 9x + 400 - 5x = 540$$

$$\Rightarrow x = 35$$

$$\text{So, \% Distance covered by 10 kmph} = \frac{35}{80} \times 100 = 43.75\%$$

End of Solution

Q.4 Four girls P, Q, R and S are studying languages in a University. P is learning French and Dutch. Q is learning Chinese and Japanese. R is learning Spanish and French. S is learning Dutch and Japanese.

Given that: French is easier than Dutch; Chinese is harder than Japanese; Dutch is easier than Japanese, and Spanish is easier than French.

Based on the above information, which girl is learning the most difficult pair of languages?

- (a) P (b) Q
(c) R (d) S

Ans. (b)

Languages as per difficulty or hardness w.r.t each other

Chinese > Japanese > Dutch > French > Spanish

So, among P, Q, R and S, Q learning the most difficult languages (i.e. Chinese and Japanese).

End of Solution

Q.5

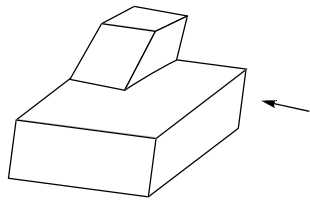

A block with a trapezoidal cross-section is placed over a block with rectangular cross section as shown above. Which one of the following is the correct drawing of the view of the 3D object as viewed in the direction indicated by an arrow in the above figure?

- (a)
- (b)
- (c)
- (d)

Ans. (a)

If viewed from the direction stated above, the 2-D view will appear as a trapezium placed over a rectangle.

End of Solution

Q.6 Humans are naturally compassionate and honest. In a study using strategically placed wallets that appear "lost", it was found that wallets with money are more likely to be returned than wallets without money. Similarly, wallets that had a key and money are more likely to be returned than wallets with the same amount of money alone. This suggests that the primary reason for this behavior is compassion and empathy.

Which one of the following is the CORRECT logical inference based on the information in the above passage?

- (a) Wallets with a key are more likely to be returned because people do not care about money.
- (b) Wallets with a key are more likely to be returned because people relate to suffering of others.
- (c) Wallets used in experiments are more likely to be returned than wallets that are really lost.
- (d) Money is always more important than keys.

Ans. (b)

End of Solution

Q.7 A rhombus is formed by joining the midpoints of the sides of a unit square. What is the diameter of the largest circle that can be inscribed within the rhombus?

- (a) $\frac{1}{\sqrt{2}}$
- (b) $\frac{1}{2\sqrt{2}}$
- (c) $\sqrt{2}$
- (d) $2\sqrt{2}$

Ans. (a)

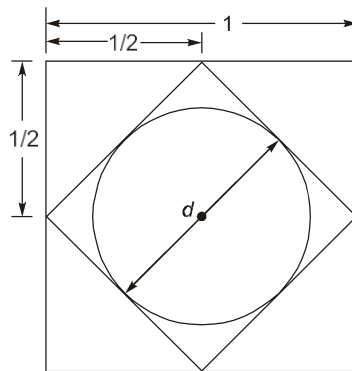

Diameter of circle = Side of rhombus

$$d = \sqrt{\left(\frac{1}{2}\right)^2 + \left(\frac{1}{2}\right)^2} = \frac{\sqrt{2}}{2} = \frac{1}{\sqrt{2}}$$

End of Solution

Q.8 An equilateral triangle, a square and a circle have equal areas. What is the ratio of the perimeters of the equilateral triangle to square to circle?

- (a) $3\sqrt{3}:2:\pi$ (b) $\sqrt{(3\sqrt{3})}:2:\sqrt{\pi}$
 (c) $\sqrt{(3\sqrt{3})}:4:2\sqrt{\pi}$ (d) $\sqrt{(3\sqrt{3})}:2:2\sqrt{\pi}$

Ans. (b)

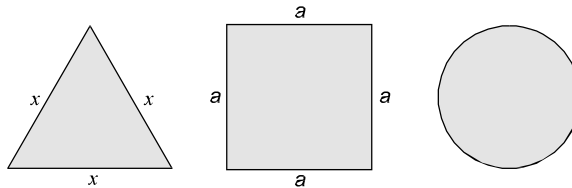

Area:

$$\frac{\sqrt{3}}{4}x^2 = a^2 = \pi R^2$$

or

$$\frac{3^{1/4}}{2}x = a = \sqrt{\pi}R = k$$

Perimeter:

$$3x : 4a : 2\pi R$$

$$\frac{3 \cdot 2k}{3^{1/4}} : 4k : 2\pi \frac{k}{\sqrt{\pi}}$$

$$\sqrt{(3\sqrt{3})} : 2 : \sqrt{\pi}$$

End of Solution

Q.9 Given below are three conclusions drawn based on the following three statements.

Statement 1: All teachers are professors.

Statement 2: No professor is a male.

Statement 3: Some males are engineers.

Conclusion I: No engineer is a professor.

Conclusion II: Some engineers are professors.

Conclusion III: No male is a teacher.

Which one of the following options can be logically inferred?

- (a) Only conclusion III is correct
 (b) Only conclusion I and conclusion II are correct
 (c) Only conclusion II and conclusion III are correct
 (d) Only conclusion I and conclusion III are correct

Ans. (a)

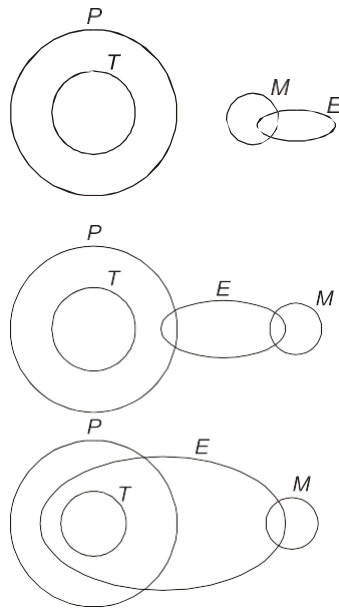

∴ Only III conclusion is correct, i.e. no male is a teacher.

End of Solution

Q.10 In a 12-hour clock that runs correctly, how many times do the second, minute, and hour hands of the clock coincide, in a 12-hour duration from 3 PM in a day to 3 AM the next day?

- (a) 11 (b) 12
(c) 144 (d) 2

Ans. (a)

Every 1 hr coincide → 1 time and in 12 h coincides → 11 time because between 11 to 1 they only meet one time.

End of Solution



SECTION - B

TECHNICAL

Q.11 The limit

$$\rho = \lim_{x \rightarrow \pi} \left(\frac{x^2 + ax + 2\pi^2}{x - \pi + 2\sin x} \right)$$

has a finite value of real α . The value of α and the corresponding limit ρ are

- (a) $\alpha = -3\pi$, and $\rho = \pi$
- (b) $\alpha = -2\pi$, and $\rho = 2\pi$
- (c) $\alpha = \pi$, and $\rho = \pi$
- (d) $\alpha = 2\pi$, and $\rho = 3\pi$

Ans. (a)

Given,
$$\rho = \lim_{x \rightarrow \pi} \frac{x^2 + ax + 2\pi^2}{x - \pi + 2\sin x}$$

For $x = \pi$, the denominator becomes zero. Thus for ρ to have a finite value, the numerator must also be zero for $x = \pi$.

\Rightarrow At $x = \pi$,

$$\begin{aligned} \pi^2 + a\pi + 2\pi^2 &= 0 \\ a\pi &= -3\pi^2 \\ a &= -3\pi \end{aligned}$$

Now,
$$\rho = \lim_{x \rightarrow \pi} \frac{x^2 + 3\pi x + 2\pi^2}{x - \pi + 2\sin x} \left(\frac{0}{0} \text{ form} \right)$$

Using L' Hospital's rule,

$$\begin{aligned} \rho &= \lim_{x \rightarrow \pi} \frac{2x - 3\pi}{1 + 2\cos x} \\ \rho &= \frac{2\pi - 3\pi}{1 + 2\cos \pi} = \frac{-\pi}{1 - 2} = \pi \\ \therefore \rho &= \pi \end{aligned}$$

End of Solution

Q.12 Solution of $\nabla^2 T = 0$ in a square domain ($0 < x < 1$ and $0 < y < 1$) with boundary conditions:

$$T(x, 0) = x; \quad T(0, y) = y; \quad T(x, 1) = 1 + x; \quad T(1, y) = 1 + y$$

is

- (a) $T(x, y) = x - xy + y$
- (b) $T(x, y) = x + y$
- (c) $T(x, y) = -x + y$
- (d) $T(x, y) = x + xy + y$

Ans. (b)

For boundary condition,

$$T(x, 1) = x + 1$$

Option A

$$T(x, 1) = x - x \times 1 + 1 = 1 \neq x + 1 \text{ not satisfy}$$

Option B

$$T(x, 1) = x + 1 \text{ satisfy}$$

Option C

$$T(x, 1) = -x + 1 \text{ not satisfy}$$

Option D

$$T(x, 1) = x + x(1) = 2x + 1 \text{ not satisfy}$$

Hence correction option is B.

End of Solution

Q.13 Given a function $\phi = \frac{1}{2}(x^2 + y^2 + z^2)$ in three-dimensional Cartesian space, the value of the surface integral

$$\oiint_S \hat{n} \cdot \nabla \phi dS,$$

where S is the surface of a sphere of unit radius and \hat{n} is the outward unit normal vector on S , is

(a) 4π

(b) 3π

(c) $\frac{4\pi}{3}$

(d) 0

Ans. (a)

Given,

$$\phi = \frac{1}{2}(x^2 + y^2 + z^2)$$

$$\bar{\nabla} \phi = \frac{\partial \phi}{\partial x} i + \frac{\partial \phi}{\partial y} j + \frac{\partial \phi}{\partial z} k$$

$$\bar{\nabla} \phi = \frac{1}{2}(2xi + 2yj + 2zk)$$

$$\bar{\nabla} \phi = xi + yj + zk$$

Using Gauss' divergence theorem,

$$\begin{aligned} \oiint_S \hat{n} \cdot \nabla \phi ds &= \iiint_V \bar{\nabla} \cdot (\bar{\nabla} \phi) dV \\ &= \iiint_V \bar{\nabla} \cdot (xi + yj + zk) dV \end{aligned}$$

$$\begin{aligned}
&= \iiint_V (1+1+1) dV = 3 \iiint_V dV \\
&= 3 \times \text{volume of sphere} \\
&= 3 \times \frac{4}{3} \pi (1)^3 = 4\pi
\end{aligned}$$

End of Solution

- Q.14** The Fourier series expansion of x^3 in the interval $-1 \leq x \leq 1$ with periodic continuation has
- (a) only sine terms
 - (b) only cosine terms
 - (c) both sine and cosine terms
 - (d) only sine terms and a non-zero constant

Ans. (a)

Since $f(x) = x^3$ is an odd function, its Fourier series expansion consists of only sine terms.

End of Solution

- Q.15** If $A = \begin{bmatrix} 10 & 2k+5 \\ 3k-3 & k+5 \end{bmatrix}$ is a symmetric matrix, the value of k is _____.

- (a) 8
- (b) 5
- (c) -0.4
- (d) $\frac{1+\sqrt{1561}}{12}$

Ans. (a)

For the matrix to be symmetric,

$$\begin{aligned}
& a_{12} = a_{21} \\
\Rightarrow & 2k + 5 = 3k - 3 \\
\Rightarrow & k = 8
\end{aligned}$$

End of Solution

- Q.16** A uniform light slender beam AB of section modulus EI is pinned by a frictionless joint A to the ground and supported by a light inextensible cable CB to hang a weight W as shown. If the maximum value of W to avoid buckling of the beam AB is obtained as $\beta\pi^2 EI$, where π is the ratio of circumference to diameter of a circle, then the value of β is

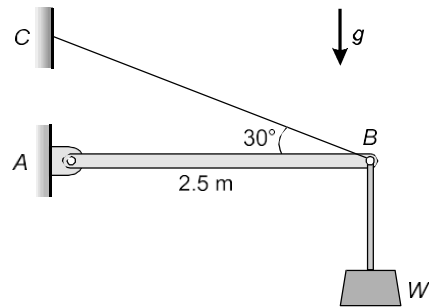

- (a) 0.0924 m^{-2}
- (b) 0.0713 m^{-2}
- (c) 0.1261 m^{-2}
- (d) 0.1417 m^{-2}

Ans. (a)

Drawing free body diagram of point B,

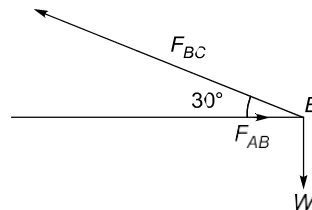

Writing two equations for equilibrium at point B.

$$\Rightarrow F_{BC} (\sin 30^\circ) = W$$

$$F_{BC} = 2W$$

$$F_{AB} = F_{BC} \cos 30^\circ$$

$$F_{AB} = 2W \cos 30^\circ$$

$$F_{AB} = 2W \times \frac{\sqrt{3}}{2}$$

$$F_{AB} = 1.732W$$

Using the standard formula for buckling load,

$$P_C = \frac{\pi^2 EI}{L_C^2} = \frac{\pi^2 EI}{(2.5)^2}$$

$$F_{AB} = 1.732W = \frac{\pi^2 EI}{(2.5)^2}$$

$$W = \frac{\pi^2 EI}{(2.5)^2 \times 1.732} = \beta \pi^2 EI$$

$$\beta = \frac{1}{1.732 \times 6.25} = 0.092$$

End of Solution

- Q.17** The figure shows a schematic of a simple Watt governor mechanism with the spindle O_1O_2 rotating at an angular velocity ω about a vertical axis. The balls at P and S have equal mass. Assume that there is no friction anywhere and all other components are massless and rigid. The vertical distance between the horizontal plane of rotation of the balls and the pivot O_1 is denoted by h . The value of $h = 400$ mm at a certain ω . If ω is doubled, the value of h will be _____ mm.

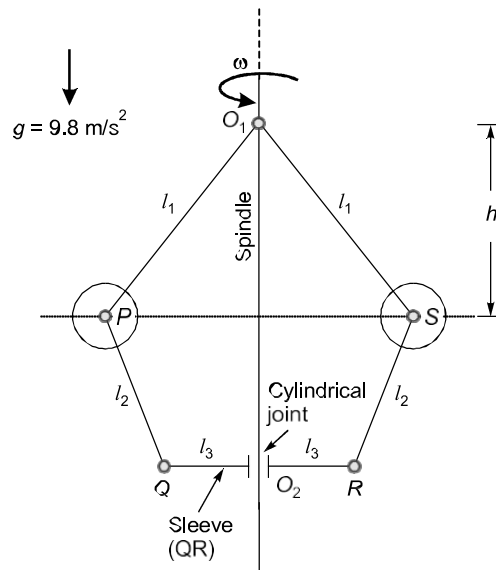

- (a) 50
 (b) 100
 (c) 150
 (d) 200

Ans. (b)

For a Watt governor:

$$\Rightarrow \omega^2 = \frac{g}{h}$$

$$\Rightarrow h \propto \frac{1}{\omega^2}$$

$$\Rightarrow \frac{h_1}{h_2} = \frac{\omega_2^2}{\omega_1^2}$$

$$\Rightarrow \frac{400}{h_2} = \frac{(2\omega_1)^2}{\omega_1^2} = 4$$

$$\Rightarrow h_2 = \frac{400}{4} = 100 \text{ mm}$$

End of Solution

Q.18 A square threaded screw is used to lift a load W by applying a force F . Efficiency of square threaded screw is expressed as

(a) The ratio of work done by W per revolution to work done by F per revolution

(b) $\frac{W}{F}$

(c) $\frac{F}{W}$

(d) The ratio of work done by F per revolution to work done by W per revolution

Ans. (a)

$$\text{Velocity ratio} = \frac{\text{Velocity of } P}{\text{Velocity of } W} = \frac{x}{y} \text{ (say)}$$

$$\text{Mechanical advantage, } MA = \frac{F_{\text{output}}}{F_{\text{input}}} = \frac{W}{F}$$

$$\eta = \frac{\text{Work done by machine on load}}{\text{Work done by effort}}$$

$$= \frac{W \cdot y}{F \cdot x}$$

$$\eta = \frac{\text{Work done by } W \text{ per revolution}}{\text{Work done by } F \text{ per revolution}}$$

End of Solution

Q.19 A CNC worktable is driven in a linear direction by a lead screw connected directly to a stepper motor. The pitch of the lead screw is 5 mm. The stepper motor completes one full revolution upon receiving 600 pulses. If the worktable speed is 5 m/minute and there is no missed pulse, then the pulse rate being received by the stepper motor is

(a) 20 kHz

(b) 10 kHz

(c) 3 kHz

(d) 15 kHz

Ans. (b)

$$\text{Table speed} = \text{BLU} \times \text{Frequency } (f)$$

$$\Rightarrow f = \frac{\text{Table Speed}}{\text{B.L.U.}}$$

$$\Rightarrow \text{Given 600 pulses} = 5 \text{ mm}$$

$$\Rightarrow 1 \text{ pulse} = \frac{5}{600} \text{ mm/pulses} = \text{B.L.U.}$$

$$\therefore f = \frac{\text{T.S}}{\text{B.L.U}}$$

$$\Rightarrow f = \frac{5000 \text{ mm}}{60 \text{ sec} \times \frac{5 \text{ mm}}{600 \text{ pulses}}} = 10 \text{ kHz}$$

End of Solution

Q.20 The type of fit between a mating shaft of diameter $25.0^{+0.010}_{-0.010}$ mm and a hole of diameter $25.015^{+0.015}_{-0.015}$ mm is _____.

- (a) Clearance (b) Transition
(c) Interference (d) Linear

Ans. (b)

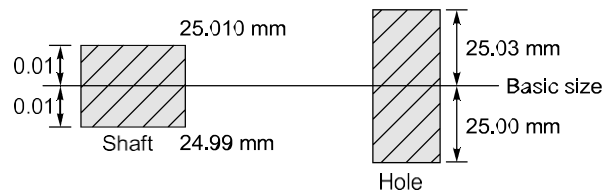

So, here we will have the transition fit which is the option (b).

End of Solution

Q.21 In a linear programming problem, if a resource is not fully utilized, the shadow price of that resource is

- (a) positive (b) negative
(c) zero (d) infinity

Ans. (c)

The shadow price indicates an additional unit of the resources in order to maximize profit under the resource constraints. If a resource is not completely used, i.e. there is slack then its marginal return is zero.

End of Solution

Q.22 Which one of the following is NOT a form of inventory?

- (a) Raw materials (b) Work-in-process materials
(c) Finished goods (d) CNC Milling Machines

Ans. (d)

CNC milling machine does not make a part of the inventory. Machines come under asset category.

End of Solution

Q.23 The Clausius inequality holds good for

- (a) any process
- (b) any cycle
- (c) only reversible process
- (d) only reversible cycle

Ans. (b)

Clausius inequality is given as:

$$\oint \frac{dQ}{T} \leq 0$$

It is given as

$$\oint \frac{dQ}{T} = 0; \text{ Valid for reversible cycle}$$

$$\oint \frac{dQ}{T} < 0; \text{ Valid for irreversible cycle}$$

$$\oint \frac{dQ}{T} > 0; \text{ Not possible}$$

So, the inequality is valid for any cycle.

End of Solution

Q.24 A tiny temperature probe is fully immersed in a flowing fluid and is moving with zero relative velocity with respect to the fluid. The velocity field in the fluid is $\vec{V} = (2x)\hat{i} + (y + 3t)\hat{j}$, and the temperature field in the fluid is $T = 2x^2 + xy + 4t$, where x and y are the spatial coordinates, and t is the time. The time rate of change of temperature recorded by the probe at $(x = 1, y = 1, t = 1)$ is _____.

- (a) 4
- (b) 0
- (c) 18
- (d) 14

Ans. (c)

$$\vec{V} = (2x)\hat{i} + (y + 3t)\hat{j}, \quad T = 2x^2 + xy + 4t$$

$$\frac{DT}{Dt} = \frac{\partial T}{\partial x} \cdot \frac{dx}{dt} + \frac{\partial T}{\partial y} \cdot \frac{dy}{dt} + \frac{\partial T}{\partial t} \cdot \frac{dt}{dt}$$

$$= u \frac{\partial T}{\partial x} + v \frac{\partial T}{\partial y} + \frac{\partial T}{\partial t}$$

$$= 2x(4x + y) + (y + 3t)x + 4$$

Put $x = 1, y = 1; \quad t = 1$

$$\left(\frac{DT}{Dt} \right)_{\substack{x=1 \\ y=1 \\ t=1}} = 2(4 + 1) + (1 + 3)1 + 4$$

$$= 10 + 4 + 4 = 18$$

End of Solution

- Q.25** In the following two-dimensional momentum equation for natural convection over a surface immersed in a quiescent fluid at temperature T_∞ (g is the gravitational acceleration, β is the volumetric thermal expansion coefficient, ν is the kinematic viscosity, u and v are the velocities in x and y directions, respectively, and T is the temperature)

$$u \frac{\partial u}{\partial x} + v \frac{\partial u}{\partial y} = g\beta(T - T_\infty) + \nu \frac{\partial^2 u}{\partial y^2},$$

the term $g\beta(T - T_\infty)$ represents

- (a) Ratio of inertial force to viscous force.
- (b) Ratio of buoyancy force to viscous force.
- (c) Viscous force per unit mass.
- (d) Buoyancy force per unit mass.

Ans. (d)

$$\beta = \frac{1}{V} \frac{\partial V}{\partial T}$$

β is the volumetric thermal expansion which, signify the buoyancy forces

the term $g\beta(T - T_\infty)$ represents Buoyant force per unit mass.

End of Solution

- Q.26** Assuming the material considered in each statement is homogeneous, isotropic, linear elastic, and the deformations are in the elastic range, which one or more of the following statement(s) is/are TRUE?

- (a) A body subjected to hydrostatic pressure has no shear stress.
- (b) If a long solid steel rod is subjected to tensile load, then its volume increases.
- (c) Maximum shear stress theory is suitable for failure analysis of brittle materials.
- (d) If a portion of a beam has zero shear force, then the corresponding portion of the elastic curve of the beam is always straight.

Ans. (a, b)

Under hydrostatic stress state condition, Mohr's circle will become a point. Every plane will become a principal plane and on all the principal planes, shear stress is zero. So, the statement is correct.

Under axial tensile load, volume of rod increases because longitudinal and lateral strains are tensile and compressive in the nature respectively and longitudinal strain more than lateral strain. So this statement is correct.

Maximum shear stress theory is more suitable for ductile materials, not for brittle materials. For brittle materials, the maximum principle stress theory is suitable. So, this statement is also increased.

When shear force and bending moment both are zero, then elastic curve will be a straight line. When shear force is zero and bending moment has a constant non-zero value, then elastic curve will be a circular arc. Hence, the last statement is not correct.

End of Solution

Q.27 Which of the following heat treatment processes is/are used for surface hardening of steels?

- (a) Carburizing
- (b) Cyaniding
- (c) Annealing
- (d) Carbonitriding

Ans. (a, b, d)

We know that annealing reduces the hardness, but processes like carburising, carbonitriding and nitriding increases the surface hardness.

End of Solution

Q.28 Which of the following additive manufacturing technique(s) can use a wire as a feedstock material?

- (a) Stereolithography
- (b) Fused deposition modeling
- (c) Selective laser sintering
- (d) Directed energy deposition processes

Ans. (b, d)

In stereolithography, liquid form of the polymer material is there and ultraviolet radiation falls upon the material. Due to this, one layer of material would be deposited. So, layer by layer deposition takes place. Here, wire feed is not used.

In fused deposition modelling (FDM), space of wire of ABS material is passed through heated rollers.

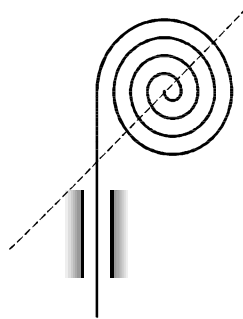

Now, this semi-solid material gets deposited.

In selective laser sintering, a bed of powder polymer, resin or metal is targeted partially (sintering) or fully (melting) by a high-power directional heating source such as laser that result to a solidified layer of fused powder.

In directed energy deposition process, feed stock material is in the form of wire or powder form is used.

End of Solution

Q.29 Which of the following methods can improve the fatigue strength of a circular mild steel (MS) shaft?

- (a) Enhancing surface finish
- (b) Shot peening of the shaft
- (c) Increasing relative humidity
- (d) Reducing relative humidity

Ans. (a, b, d)

Surface roughness increases surface notches which will make more cracks. Fatigue strength is decreased. Therefore, enhanced surface finish will increase fatigue strength.

Shot peening induces the surface compressive residual stresses and these stresses do not allow crack propagation to take place. Shot peening increases fatigue strength.

Humidity can cause corrosion, so if humidity is there, it may lead to more crack formation. Therefore, fatigue strength increases when relative humidity decreases.

End of Solution

Q.30 The figure shows a purely convergent nozzle with a steady, inviscid compressible flow of an ideal gas with constant thermophysical properties operating under choked condition. The exit plane shown in the figure is located within the nozzle. If the inlet pressure (P_0) is increased while keeping the back pressure (P_{back}) unchanged, which of the following statements is/are true?

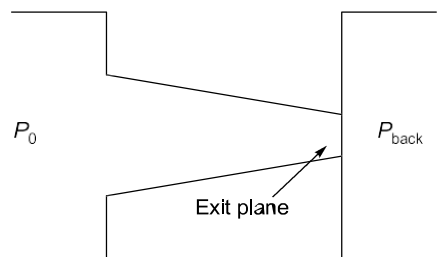

- (a) Mass flow rate through the nozzle will remain unchanged.
- (b) Mach number at the exit plane of the nozzle will remain unchanged at unity.
- (c) Mass flow rate through the nozzle will increase.
- (d) Mach number at the exit plane of the nozzle will become more than unity.

Ans. (b, c)

Now, P_0 is measured and P_b is unchanged, due to choked condition, mass flow rate through exit plane will first increase and then will become maximum.

Mach number corresponding to maximum mass flow will be unity.

End of Solution

Q.31 The plane of the figure represents a horizontal plane. A thin rigid rod at rest is pivoted without friction about a fixed vertical axis passing through O . Its mass moment of inertia is equal to $0.1 \text{ kg}\cdot\text{cm}^2$ about O . A point mass of 0.001 kg hits it normally at 200 cm/s at the location shown, and sticks to it. Immediately after the impact, the angular velocity of the rod is _____ rad/s (in integer).

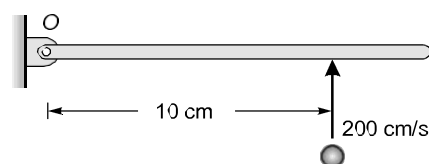

Ans. (10)

Taking rod and mass m as the system and using the principle of conservation of angular momentum about point O .

$$\Rightarrow L_{A, \text{ before striking}} = L_{A, \text{ after striking}}$$

$$\Rightarrow mVr = (I_{\text{combined}})\omega$$

$$\Rightarrow 0.001 \times 200 \times 10 = (0.1 \times 0.001 \times 10^2) \times \omega$$

$$\Rightarrow \omega = \frac{2}{0.2} = 10 \text{ rad/s}$$

End of Solution

- Q.32 A rigid uniform annular disc is pivoted on a knife edge A in a uniform gravitational field as shown, such that it can execute small amplitude simple harmonic motion in the plane of the figure without slip at the pivot point. The inner radius r and outer radius R are such that $r^2 = \frac{R^2}{2}$, and the acceleration due to gravity is g . If the time period of small amplitude simple harmonic motion is given by $T = \beta\pi\sqrt{\frac{R}{g}}$, where π is the ratio of circumference to diameter of a circle, then $\beta = \underline{\hspace{2cm}}$. (round off to 2 decimal places).

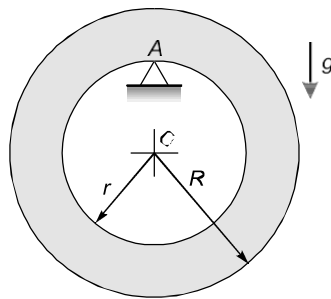

Ans. (2.66)

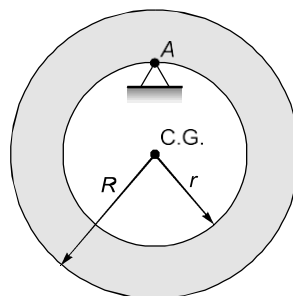

Here the disk will oscillate about the hinge which is on the smaller radius of the body. To calculate the time period, we need to first calculate the mass moment of inertia about the hinge point A . For that, we need to calculate moment of inertia about centre of gravity and then use parallel axis theorem to calculate the moment of inertia about the hinge point.

Calculation of mass moment of inertia of disk about centre of gravity axis perpendicular to the plane of the disk.

Considering a differential ring of thickness ' dx ' at a radius of x .

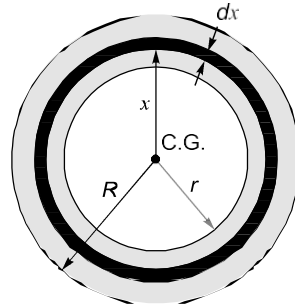

⇒ Suppose ' m ' is the mass of the disk.

⇒ Area of the disk will be $\pi(R^2 - r^2)$

⇒ Mass per unit area will be $\frac{m}{\pi(R^2 - r^2)}$

∴ So, mass of the differential element will be

$$dM = \frac{m}{\pi(R^2 - r^2)} \times 2\pi x dx = \frac{2m}{(R^2 - r^2)} x dx$$

∴ Moment of inertia of this differential disk will be

$$\Rightarrow dI_{cg} = (d_m)x^2 = \frac{2m}{(R^2 - r^2)} x dx \times x^2$$

$$\Rightarrow I_{cg} = \int_r^R \frac{2m}{R^2 - r^2} x^3 dx$$

$$\Rightarrow I_{cg} = \frac{2m}{R^2 - r^2} \int_r^R x^3 dx$$

$$\Rightarrow I_{cg} = \frac{2m}{R^2 - r^2} \left[\frac{x^4}{4} \right]_r^R = \frac{2m}{R^2 - r^2} \left(\frac{1}{4} \right) (R^4 - r^4)$$

$$\Rightarrow I_{cg} = \frac{2m}{R^2 - r^2} \times \frac{1}{4} (R^4 + r^4) (R^2 - r^2)$$

$$\Rightarrow I_{cg} = \frac{m}{2} (R^2 + r^2)$$

Putting the relation given

$$r = \frac{R}{\sqrt{2}}$$

We get,
$$I_{cg} = \frac{3}{4} m R^2$$

⇒ Using parallel axis theorem to get mass moment of inertia about the hinge point A, perpendicular to the plane.

$$\Rightarrow I_A = I_{CG} + mr^2$$

$$\Rightarrow I_A = \frac{3}{4}mR^2 + mr^2$$

$$= \frac{3}{4}mR^2 + \frac{mR^2}{2} = \frac{5}{4}mR^2$$

∴ Applying torque method to calculate the time period. Let the disk be disturbed by a small amount (θ) in anti-clockwise direction. So, there would be a torque due to mg in clockwise direction.

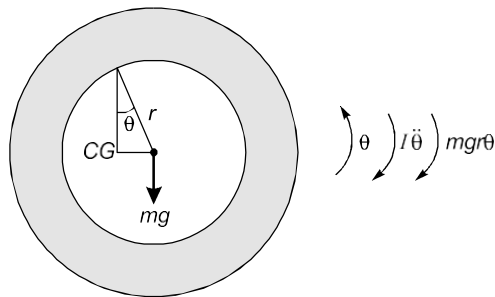

⇒ Applying D’Alambert’s principle

$$\Rightarrow I\ddot{\theta} + mgr \sin\theta = 0 \quad [\sin\theta \approx \theta]$$

$$\Rightarrow \frac{5}{4}mR^2\ddot{\theta} + mg\frac{R}{\sqrt{2}}\theta = 0$$

$$\Rightarrow \ddot{\theta} + \frac{4g}{5\sqrt{2}R}\theta = 0 \quad \text{Equation of motion}$$

⇒ Standard form of oscillation is given as:

$$\ddot{\theta} + \omega_n^2\theta = 0$$

Comparing the equations, we get

$$\omega_n^2 = \frac{4g}{5\sqrt{2}R}$$

$$\omega_n = \frac{2}{\sqrt{5\sqrt{2}}}\sqrt{\frac{g}{R}}$$

Time period is given as

$$T = \frac{2\pi}{\omega_n} = \frac{2\pi}{\frac{2}{\sqrt{5\sqrt{2}}}\sqrt{\frac{g}{R}}} = \sqrt{5\sqrt{2}}\pi\sqrt{\frac{R}{g}}$$

⇒ Comparing the equation with the time period given in the question, we get

$$\beta = \sqrt{5\sqrt{2}}$$

$$= 2.659 \approx 2.66$$

End of Solution

Q.33 Electrochemical machining operations are performed with tungsten as the tool, and copper and aluminum as two different workpiece materials. Properties of copper and aluminum are given in the table below.

Material	Atomic mass (amu)	Valency	Density (g/cm ³)
Copper	63	2	9
Aluminium	27	3	2.7

Ignore overpotentials, and assume that current efficiency is 100% for both the workpiece materials. Under identical conditions, if the material removal rate (MRR) of copper is 100 mg/s, the MRR of aluminum will be _____ mg/s (round-off to two decimal places).

Ans. (28.57)

Material removal rate in ECM is given as $MRR \text{ (gm/sec)} = \frac{eI}{F}$

⇒ Using the equation for copper

$$\Rightarrow MRR \text{ (gm/sec)} = \frac{eI}{F}$$

$$\Rightarrow 100 \times 10^{-3} = \frac{\frac{63}{2} \times I}{96500}$$

$$\Rightarrow I = 306.35 \text{ Amperes}$$

Using the equation for aluminium

$$\begin{aligned} \Rightarrow MRR \text{ (gm/sec)} &= \frac{eI}{F} = \frac{\frac{27}{3} \times 306.35}{96500} \text{ gm/sec} \\ &= 0.028 \text{ gm/sec} = 28.57 \text{ mg/sec} \end{aligned}$$

End of Solution

Q.34 A polytropic process is carried out from an initial pressure of 110 kPa and volume of 5 m³ to a final volume of 2.5 m³. The polytropic index is given by $n = 1.2$. The absolute value of the work done during the process is _____ kJ (round off to 2 decimal places).

Ans. (408.92)

$$P_1 V_1^{1.2} = P_2 V_2^{1.2}$$

$$110(5)^{1.2} = P_2(2.5)^{1.2}$$

$$P_2 = 252.7136 \text{ kPa}$$

$$W = \frac{P_1 V_1 - P_2 V_2}{n-1} = \frac{110 \times 5 - 252.7136 \times 2.5}{1.2-1}$$

$$W = -408.92 \text{ kJ}$$

∴ Magnitude is 408.92 kJ.

End of Solution

Q.35 A flat plate made of cast iron is exposed to a solar flux of 600 W/m^2 at an ambient temperature of 25°C . Assume that the entire solar flux is absorbed by the plate. Cast iron has a low temperature absorptivity of 0.21. Use Stefan-Boltzmann constant $= 5.669 \times 10^{-8} \text{ W/m}^2\text{-K}^4$. Neglect all other modes of heat transfer except radiation. Under the aforementioned conditions, the radiation equilibrium temperature of the plate is _____ $^\circ\text{C}$ (round off to the nearest integer).

Ans. (218)

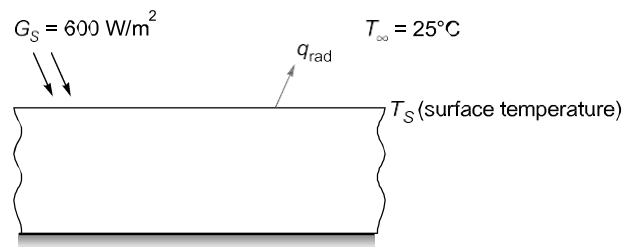

For steady state of slab,

Heat absorbed by plate = Net radiation heat transfer between plate and ambient
As per Kirchoff's law,

$$\begin{aligned} &= \alpha_{\text{Sky}} = \epsilon_{\text{Sky}} \\ \epsilon &= 0.21 \end{aligned}$$

For equilibrium temperature :

Net heat transfer at surface = 0

$$q''_{\text{rad}} - G_s = 0$$

$$\epsilon\sigma(T^4 - T_\infty^4) = G_s$$

$$0.21 \times 5.67 \times 10^{-8} [T^4 - 298^4] = 600$$

$$T = 491.33 \text{ K}$$

$$T = 218^\circ\text{C}$$

End of Solution

Q.36 The value of the integral

$$\oint \left(\frac{6z}{2z^4 - 3z^3 + 7z^2 - 3z + 5} \right) dz$$

evaluated over a counter-clockwise circular contour in the complex plane enclosing only the pole $z = i$, where i is the imaginary unit, is

(a) $(-1 + i)\pi$

(b) $(1 + i)\pi$

(c) $2(1 - i)\pi$

(d) $(2 + i)\pi$

Ans. (a)

Let,

$$f(z) = 2z^4 - 3z^3 + 7z^2 - 3z + 5$$

Here,

$$f(i) = 2i^4 - 3i^3 + 7i^2 - 3i + 5$$

$$= 2(1) - 3(-i) + 7(-1) - 3i + 5$$

$$= 2 + 3i - 7 - 3i + 5 = 0$$

∴ $z = i$ is a singular point

$$\text{Thus, } \oint \frac{6z}{2z^4 - 3z^3 + 7z^2 - 3z + 5} dz = 2\pi i (\text{Res}|_{z=i})$$

where,

$$\text{Res}|_{z=i} = \lim_{z \rightarrow i} (z-i) \frac{6z}{2z^4 - 3z^3 + 7z^2 - 3z + 5}$$

$$= \lim_{z \rightarrow i} \frac{6z^2 - 6zi}{2z^4 - 3z^3 + 7z^2 - 3z + 5} \left(\frac{0}{0} \text{ form} \right)$$

$$= \lim_{z \rightarrow i} \frac{12z - 6i}{8z^3 - 9z^2 + 14z - 3} = \frac{12i - 6i}{8i^3 - 9i^2 + 14i - 3}$$

$$= \frac{6i}{8(-i) - 9(-1) + 14i - 3} = \frac{6i}{6 + 6i} = \frac{i}{i+1}$$

$$\therefore \oint \frac{6z}{2z^4 - 3z^3 + 7z^2 - 3z + 5} dz = 2\pi i \left(\frac{i}{i+1} \right)$$

$$= \frac{2\pi(-1)}{i+1} = \frac{-2\pi}{i+1} \times \frac{i-1}{i-1}$$

$$= \frac{-2\pi(i-1)}{i^2 - 1} = \frac{-2\pi(i-1)}{-2}$$

$$= (-1 + i)\pi$$

End of Solution

Q.37 An L-shaped elastic member ABC with slender arms AB and BC of uniform cross-section is clamped at end A and connected to a pin at end C . The pin remains in continuous contact with and is constrained to move in a smooth horizontal slot. The section modulus of the member is same in both the arms. The end C is subjected to a horizontal force P and all the deflections are in the plane of the figure. Given the length AB is 4α and length BC is α , the magnitude and direction of the normal force on the pin from the slot, respectively, are

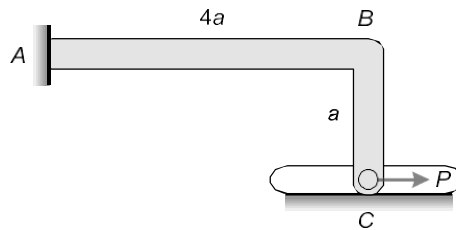

- (a) $\frac{3P}{8}$, and downwards
- (b) $\frac{5P}{8}$, and upwards
- (c) $\frac{P}{4}$, and downwards
- (d) $\frac{3P}{4}$, and upwards

Ans. (a)

Free body diagram of the member is:

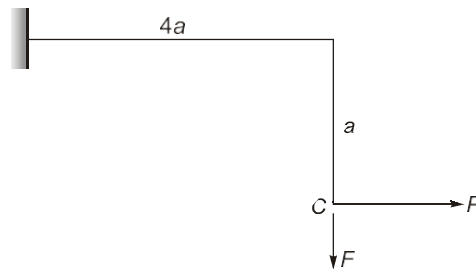

Where F is the force at point C which will move member downwards.

Let,

ΔC_1 = Deflection upwards by force P

ΔC_2 = Deflection downwards by force F

$$\Delta C_1 = \frac{(Pa)(4a)^2}{2EI} = \frac{8Pa^3}{EI}$$

$$\Delta C_2 = \frac{F \times (4a)^3}{3EI} = \frac{64Fa^3}{3EI}$$

As,

$$\Delta C_1 = \Delta C_2$$

$$\Rightarrow \frac{8Pa^3}{EI} = \frac{64Fa^3}{3EI}$$

$$\Rightarrow F = \frac{24P}{64} = \frac{3P}{8} \text{ (downwards)}$$

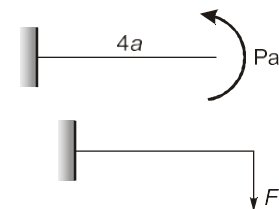

End of Solution

Q.38 A planar four-bar linkage mechanism with 3 revolute kinematic pairs and 1 prismatic kinematic pair is shown in the figure, where $AB \perp CE$ and $FD \perp CE$. The T-shaped link $CDEF$ is constructed such that the slider B can cross the point D , and CE is sufficiently long. For the given lengths as shown, the mechanism is

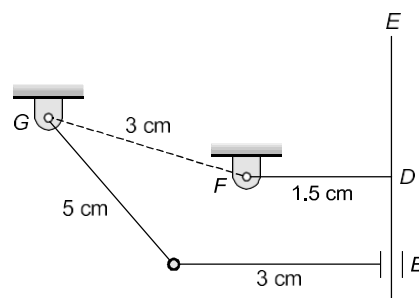

- a Grashof chain with links AG , AB , and $CDEF$ completely rotatable about the ground link FG
- a non-Grashof chain with all oscillating links
- a Grashof chain with AB completely rotatable about the ground link FG , and oscillatory links AG and $CDEF$
- on the border of Grashof and non-Grashof chains with uncertain configuration(s)

Now,

$$\omega_p = (\sqrt{1-2\zeta^2}) \cdot \omega_n$$

And,

$$\omega_d = (\sqrt{1-2\zeta^2}) \cdot \omega_n$$

Therefore,
In general,

$$\omega_d < \omega_n$$

$$\omega_p < \omega_n$$

and

$$\omega_p < \omega_d$$

⇒

$$\omega_p < \omega_d < \omega_n$$

Therefore, option (a) is correct answer.

End of Solution

- Q.40** A bracket is attached to a vertical column by means of two identical rivets U and V separated by a distance of $2a = 100$ mm, as shown in the figure. The permissible shear stress of the rivet material is 50 MPa. If a load $P = 10$ kN is applied at an eccentricity $e = 3\sqrt{7}a$, the minimum cross-sectional area of each of the rivets to avoid failure is _____ mm².

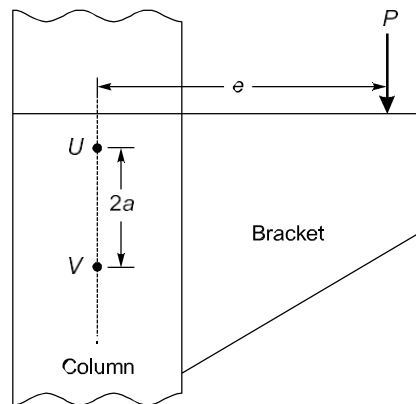

- (a) 800
(b) 25
(c) $100\sqrt{7}$
(d) 200

Ans. (a)

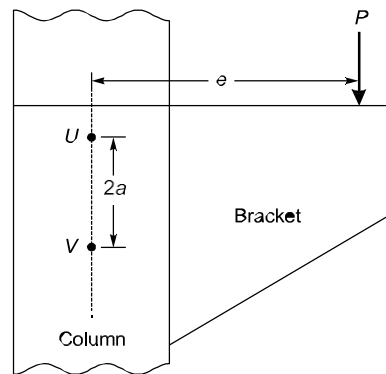

$$2a = 100 \text{ mm}$$

$$a = 50 \text{ mm}$$

⇒
Primary forces

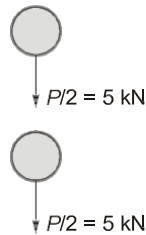

Secondary forces

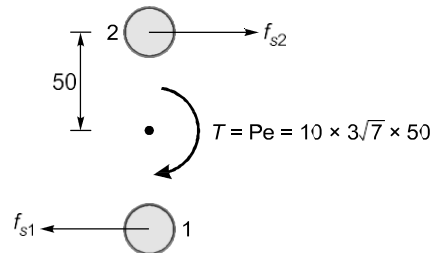

$$f_s \propto r$$

and

$$f_{s1} = f_{s2} = \frac{Pe}{2r} = \frac{10 \times 3\sqrt{7} \times 50}{2 \times 50} = 39.68 \text{ kN}$$

Critical rivet both 1 and 2.

∴ Maximum shear force = Resultant of force

$$R = \sqrt{(39.68)^2 + 5^2} = 40 \text{ kN}$$

Safe condition:

$$\frac{R}{A} \leq \tau_{\text{per}}$$

$$\frac{40 \times 10^3}{A} \leq 50$$

$$A = 800 \text{ mm}^2$$

End of Solution

- Q.41** In Fe-Fe₃C phase diagram, the eutectoid composition is 0.8 weight % of carbon at 725°C. The maximum solubility of carbon in α-ferrite phase is 0.025 weight % of carbon. A steel sample, having no other alloying element except 0.5 weight % of carbon, is slowly cooled from 1000°C to room temperature. The fraction of pro-eutectoid α-ferrite in the above steel sample at room temperature is
- (a) 0.387 (b) 0.864
(c) 0.475 (d) 0.775

Ans. (a)

Below eutectoid temperature, there will not be any change in the mass fraction of Pro-eutectoid phase till room temperature.

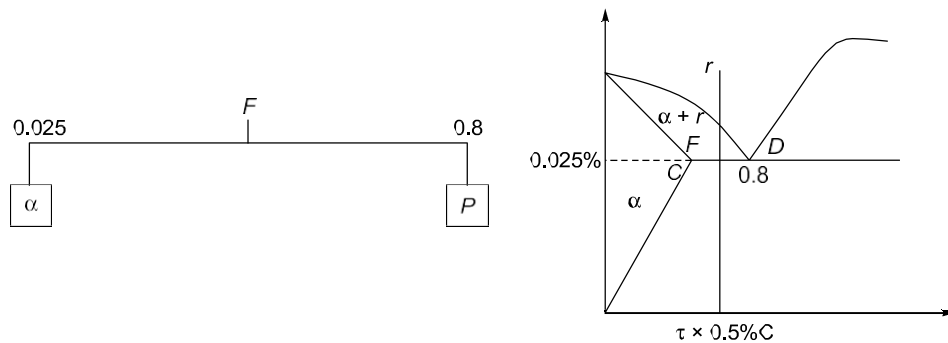

Mass fraction of pro-eutectoid α is given by $\frac{FD}{CD}$

$$\therefore \frac{FD}{CD} = \frac{0.8 - 0.5}{0.8 - 0.025} = 0.387$$

End of Solution

- Q.42** Activities A to K are required to complete a project. The time estimates and the immediate predecessors of these activities are given in the table. If the project is to be completed in the minimum possible time, the latest finish time for the activity G is _____ hours.

Activity	Time (hours)	Immediate Predecessors
A	2	—
B	3	—
C	2	—
D	4	A
E	5	B
F	4	B
G	3	C
H	10	D, E
I	5	F
J	8	G
K	3	H, I, J

- (a) 5 (b) 10
(c) 8 (d) 9

Ans. (b)

Network diagram can be formed as:

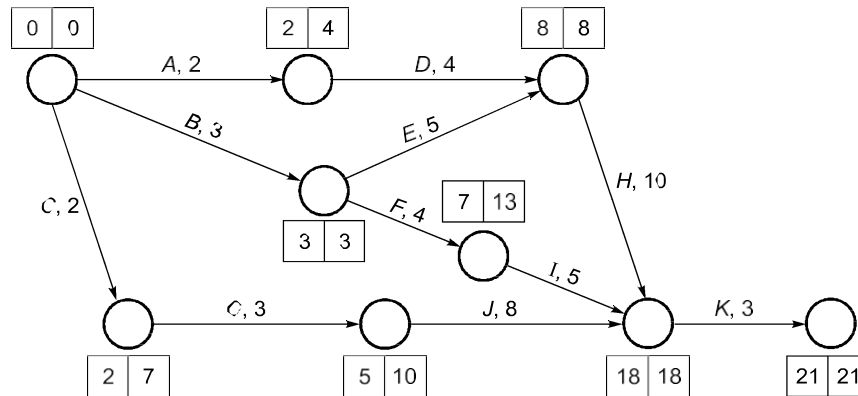

For activity G, latest finish time is 10.

End of Solution

Q.43 A solid spherical bead of lead (uniform density = 11000 kg/m^3) of diameter $d = 0.1 \text{ mm}$ sinks with a constant velocity V in a large stagnant pool of a liquid (dynamic viscosity = $1.1 \times 10^{-3} \text{ kg}\cdot\text{m}^{-1}\text{s}^{-1}$). The coefficient of drag is given by $C_D = \frac{24}{\text{Re}}$, where the Reynolds number (Re) is defined on the basis of the diameter of the bead. The drag force acting on the bead is expressed as $D = (C_D)(0.5\rho V^2)\left(\frac{\pi d^2}{4}\right)$, where ρ is the density of the liquid. Neglect the buoyancy force. Using $g = 10 \text{ m/s}^2$, the velocity V is _____ m/s.

- (a) $\frac{1}{24}$ (b) $\frac{1}{6}$
(c) $\frac{1}{18}$ (d) $\frac{1}{12}$

Ans. (c)

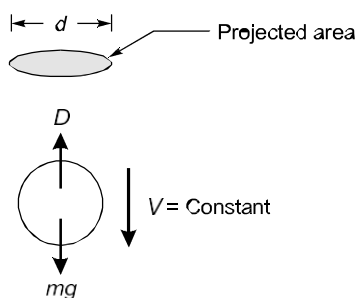

$$\begin{aligned} \text{Re} &= \frac{\rho V d}{\mu} \\ &= \frac{\rho V \times 0.1 \times 10^{-3}}{1.1 \times 10^{-3}} \\ \text{Re} &= \frac{\rho V}{11} \end{aligned}$$

$$\Rightarrow \text{Drag force on sphere} = C_D (0.5\rho V^2) \left(\frac{\pi d^2}{4} \right)$$

$$= \left(\frac{\rho V}{11} \right) (0.5\rho V^2) \left(\frac{\pi d^2}{4} \right)$$

$$D = 132V \left(\frac{\pi}{4} d^2 \right) \quad \dots(i)$$

$$\text{Weight of sphere} = \rho_{\text{Body}} g \frac{4}{3} \pi \left(\frac{d}{2} \right)^3 \quad \dots(ii)$$

For constant velocity the net force on the body must be zero.

$$D = \text{Weight}$$

$$\Rightarrow 132V \frac{\pi}{4} d^2 = \rho_{\text{Body}} g \frac{4}{3} \pi \left(\frac{d}{2} \right)^3$$

$$\Rightarrow V = \frac{11000 \times 10}{33} \times \frac{1}{6} \times 0.1 \times 10^{-3}$$

$$\therefore V = \frac{11}{33 \times 6} = \frac{1}{18}$$

End of Solution

Q.44 Consider steady, one-dimensional compressible flow of a gas in a pipe of diameter 1 m. At one location in the pipe, the density and velocity are 1 kg/m^3 and 100 m/s , respectively. At a downstream location in the pipe, the velocity is 170 m/s . If the pressure drop between these two locations is 10 kPa , the force exerted by the gas on the pipe between these two locations is _____ N.

- (a) $350 \pi^2$ (b) 750π
 (c) 1000π (d) 3000

Ans. (b)

Given : Diameter of duct, $D = 1 \text{ m}$; $V_1 = 100 \text{ m/s}$; $V_2 = 170 \text{ m/s}$;
 Change in pressure, $OP = 10 \text{ kPa}$

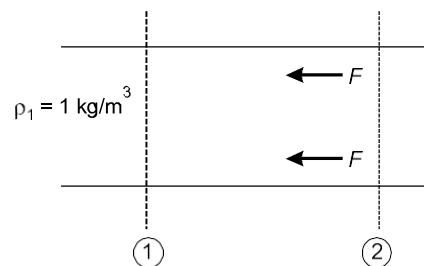

Using the momentum equation,

$$(P_1 - P_2)A - F = \dot{m}(V_2 - V_1)$$

$$\Rightarrow 10 \times 10^3 \times \frac{\pi \times 1^2}{4} - F = \rho_1 A V_1 (V_2 - V_1)$$

$$\Rightarrow 2500 \pi - F = 1 \times \frac{\pi}{4} \times 1^2 \times 100 \times (70)$$

$$\Rightarrow F = 750 \pi \text{ Newtons}$$

End of Solution

Q.45 Consider a rod of uniform thermal conductivity whose one end ($x = 0$) is insulated and the other end ($x = L$) is exposed to flow of air at temperature T_∞ with convective heat transfer coefficient h . The cylindrical surface of the rod is insulated so that the heat transfer is strictly along the axis of the rod. The rate of internal heat generation per unit volume inside the rod is given as

$$\dot{q} = \cos \frac{2\pi x}{L}$$

The steady state temperature at the mid-location of the rod is given as T_A . What will be the temperature at the same location, if the convective heat transfer coefficient increases to $2h$?

(a) $T_A + \frac{\dot{q}L}{2h}$

(b) $2T_A$

(c) T_A

(d) $T_A \left(1 - \frac{\dot{q}L}{4\pi h}\right) + \frac{\dot{q}L}{4\pi h} T_\infty$

Ans. (c)

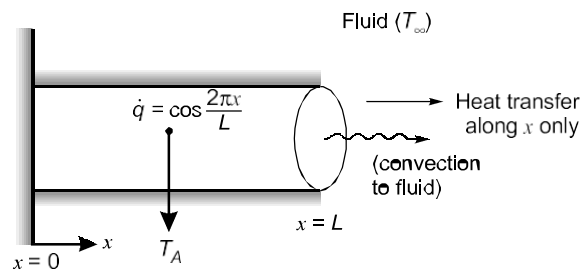

For steady state, 1-d heat flow with non-uniform heat generation.

$$\Rightarrow \frac{d^2 T}{dx^2} + \frac{\dot{q}}{k} = 0$$

$$\Rightarrow \frac{d^2 T}{dx^2} = -\frac{\dot{q}}{k}$$

Integrating the equation,

$$\Rightarrow \frac{dT}{dx} = \int -\frac{\dot{q}}{k} dx + c_1$$

$$\Rightarrow \frac{dT}{dx} = -\frac{1}{k} \int \cos \frac{2\pi x}{L} dx + c_1$$

$$\Rightarrow \frac{dT}{dx} = -\frac{1}{k} \left(\frac{L}{2\pi} \right) \sin \frac{2\pi x}{L} + c_1 \quad \dots(i)$$

At $x = 0$, $q_{\text{cond}} = 0$,

$$\frac{dT}{dx} = 0$$

$$\therefore c_1 = 0$$

Integrating (i) equation,

$$\Rightarrow T = -\frac{L}{2\pi k} \times \frac{-L}{2\pi} \cos \frac{2\pi x}{L} + c_2$$

$$\Rightarrow T = \frac{L^2}{4\pi^2 k} \cos \left(\frac{2\pi x}{L} \right) + c_2$$

At $x = L$,

\Rightarrow Heat conducted = Heat convected

$$\Rightarrow -kA \left(\frac{dT}{dx} \right)_{\text{at } x=L} = hA(T_{x=L} - T_{\infty})$$

$$\Rightarrow -k \left[-\frac{1}{k} \times \frac{L}{2\pi} \times \sin \frac{2\pi L}{L} \right] = hA(T_{x=L} - T_{\infty})$$

$$\Rightarrow -k \left[-\frac{1}{k} \times \frac{L}{2\pi} \times 0 \right] = hA(T_{x=L} - T_{\infty})$$

$$\Rightarrow T_{x=L} = T_{\infty}$$

$$\Rightarrow \frac{L^2}{4\pi^2 k} \cos \left(\frac{2\pi \times L}{L} \right) + c_2 = T_{\infty}$$

$$\Rightarrow \frac{L^2}{4\pi^2 k} + c_2 = T_{\infty}$$

Therefore, c_2 is not a function of h .

$\Rightarrow T =$ Function of x only, not h

$\therefore T_A$ remains same even if ' h ' is doubled.

End of Solution

Q.46 The system of linear equations in real (x, y) given by

$$(x \ y) \begin{bmatrix} 2 & 5-2\alpha \\ \alpha & 1 \end{bmatrix} = (0 \ 0)$$

involves a real parameter α and has infinitely many non-trivial solutions for special value(s) of α . Which one or more among the following options is/are non-trivial solution(s) of (x, y) for such special value(s) of α ?

- (a) $x = 2, y = -2$
- (b) $x = -1, y = 4$
- (c) $x = 1, y = 1$
- (d) $x = 4, y = -2$

Ans. (a, b)

For non-trivial solution,

$$|A| = 0$$

$$\Rightarrow \begin{vmatrix} 2 & 5-2a \\ a & 1 \end{vmatrix} = 0$$

$$2 - a(5 - 2a) = 0$$

$$2a - 5a + 2a^2 = 0$$

$$2a^2 - 5a + 2 = 0$$

$$2a^2 - 4a - a + 2 = 0$$

$$2a(a - 2) - (a - 2) = 0$$

$$a = 2, \frac{1}{2}$$

For $a = 2$,

$$A = \begin{bmatrix} 2 & 1 \\ 2 & 1 \end{bmatrix}$$

Thus,

$$[x \ y] \begin{bmatrix} 2 & 1 \\ 2 & 1 \end{bmatrix} = [0 \ 0]$$

$$2x + 2y = 0$$

$$\Rightarrow x + y = 0$$

$$x = -y$$

Option (a) satisfies this condition.

For, $a = \frac{1}{2}$,

$$A = \begin{bmatrix} 2 & 4 \\ \frac{1}{2} & 1 \end{bmatrix}$$

Thus,

$$[x \ y] \begin{bmatrix} 2 & 4 \\ \frac{1}{2} & 1 \end{bmatrix} = [0 \ 0]$$

$$2x + \frac{1}{2}y = 0$$

and,

$$4x + y = 0$$

$$\Rightarrow x = -\frac{y}{4}$$

Option (b) satisfies this condition.

End of Solution

Q.47 Let a random variable X follow Poisson distribution such that

$$\text{Prob}(X = 1) = \text{Prob}(X = 2)$$

The value of $\text{Prob}(X = 3)$ is (round off to 2 decimal places).

Ans. (0.18)

Given that,

$$P(x = 1) = P(x = 2)$$

$$\frac{\lambda e^{-\lambda}}{1!} = \frac{\lambda^2 e^{-\lambda}}{2!}$$

$$\lambda = \frac{\lambda^2}{2}$$

$$\lambda^2 - 2\lambda = 0$$

$$\lambda(\lambda - 2) = 0$$

$$\lambda = 2 \quad (\text{Because } \lambda \text{ cannot be zero})$$

$$\therefore P(x = 3) = \frac{e^{-2}(2)^3}{3!} = \frac{8}{6}e^{-2} = 0.180$$

End of Solution

Q.48 Consider two vectors:

$$\vec{a} = 5i + 7j + 2k$$

$$\vec{b} = 3i - j + 6k$$

Magnitude of the component of \vec{a} orthogonal to \vec{b} in the plane containing the vectors \vec{a} and \vec{b} is _____ (round off to 2 decimal places).

Ans. (8.32)

$$\vec{a} = 5\hat{i} + 7\hat{j} + 2\hat{k}$$

$$\vec{b} = 3\hat{i} - \hat{j} + 6\hat{k}$$

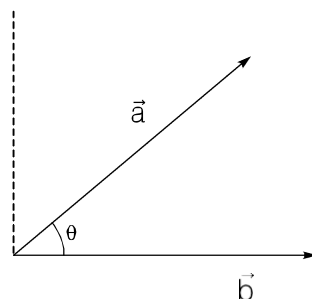

Magnitude of \vec{a} orthogonal to \vec{b} in plane of \vec{a} and $\vec{b} = \|\vec{a}\|\sin\theta$

$$\cos\theta = \frac{\vec{a} \cdot \vec{b}}{|\vec{a}| |\vec{b}|}$$

$$\Sigma M_E = 0$$

$$\Rightarrow 2 \times 1.5 - T_1 \times 1.5 + 4 \times 6 = 0$$

$$T_1 = \frac{24+3}{1.5} = \frac{27}{1.5} = 18 \text{ kN}$$

Hence, magnitude of force carried by member CI is 18 kN.

End of Solution

- Q.50** Two rigid massless rods PR and RQ are joined at frictionless pin-joint R and are resting on ground at P and Q , respectively, as shown in the figure. A vertical force F acts on the pin R as shown. When the included angle $\theta < 90^\circ$, the rods remain in static equilibrium due to Coulomb friction between the rods and ground at locations P and Q . At $\theta = 90^\circ$, impending slip occurs simultaneously at points P and Q . Then the ratio of the coefficient of friction at Q to that at P $\left(\frac{\mu_Q}{\mu_P}\right)$ is _____. (round off to two decimal places).

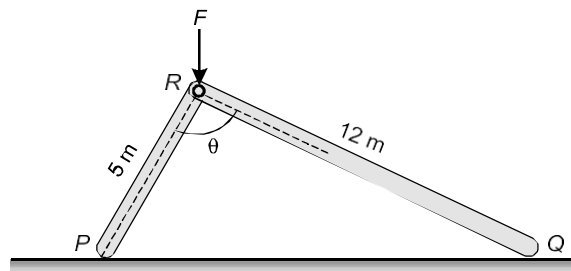

Ans. (5.76)

Considering the limiting condition at which $\theta = 90^\circ$

Let F' be the force in member PR and F'' be the force in the member QR .

Making free-body diagrams of points P and Q .

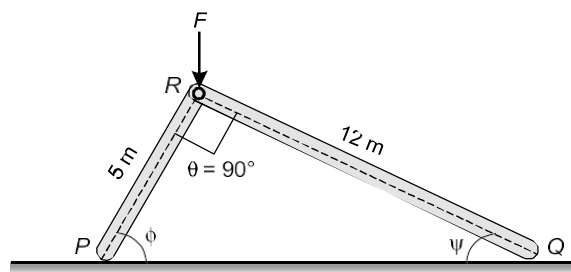

FBD of P ,

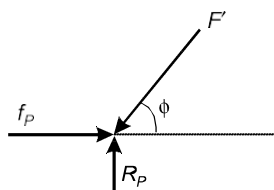

$$\begin{aligned} \Rightarrow R_P &= F' \sin \phi \\ \Rightarrow f_P &= F' \cos \phi \\ \Rightarrow \mu_P R_P &= F' \cos \phi \\ \Rightarrow \mu_P &= \frac{F' \cos \phi}{F' \sin \phi} \\ \Rightarrow \mu_P &= \frac{1}{\tan \phi} \end{aligned}$$

FBD of Q,

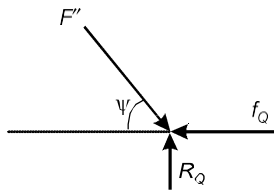

$$\begin{aligned} \Rightarrow R_Q &= F'' \sin \psi \\ \Rightarrow f_Q &= F'' \cos \psi \\ \Rightarrow \mu_Q R_Q &= F'' \cos \psi \\ \Rightarrow \mu_Q &= \frac{F'' \cos \psi}{R_Q} \\ \Rightarrow \mu_Q &= \frac{F'' \cos \psi}{F'' \sin \psi} \\ \Rightarrow \mu_Q &= \frac{1}{\tan \psi} \\ \therefore \frac{\mu_Q}{\mu_P} &= \frac{\frac{1}{\tan \psi}}{\frac{1}{\tan \phi}} = \frac{\tan \phi}{\tan \psi} \end{aligned}$$

From the given diagram

$$\begin{aligned} \Rightarrow \tan \phi &= \frac{12}{5} \\ \Rightarrow \tan \psi &= \frac{5}{12} \\ \therefore \frac{\mu_Q}{\mu_P} &= \frac{\tan \phi}{\tan \psi} = \frac{12/5}{5/12} = \frac{12}{5} \times \frac{12}{5} = 5.76 \end{aligned}$$

End of Solution

Q.51 A cylindrical disc of mass $m = 1$ kg and radius $r = 0.15$ m was spinning at $\omega = 5$ rad/s when it was placed on a flat horizontal surface and released (refer to the figure). Gravity g acts vertically downwards as shown in the figure. The coefficient of friction between the disc and the surface is finite and positive. Disregarding any other dissipation except that due to friction between the disc and the surface, the horizontal velocity of the center of the disc, when it starts rolling without slipping, will be m/s (round off to 2 decimal places).

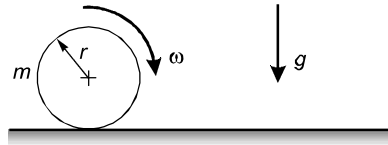

Ans. (0.25)

Given : Cylindrical disc, $m = 1$ kg, $r = 0.15$ m, initial angular speed, $\omega = 5$ rad/s

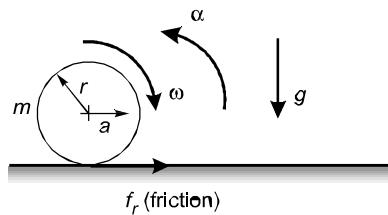

$$\begin{aligned} \Rightarrow \quad \Sigma F_x &= ma \\ \text{and} \quad f_r &= ma \quad \dots(i) \\ \Sigma \text{Torque} &= I\alpha \end{aligned}$$

$$\Rightarrow \quad f_r \times r = I\alpha \quad \left(\because I = \frac{mr^2}{2} \right)$$

$$\Rightarrow \quad f_r = \frac{mra}{2} \quad \dots(ii)$$

From equation (i) and (ii)

$$ma = \frac{mra}{2}$$

$$a = \frac{r\alpha}{2}$$

When rolling starts

$$v = \omega' r$$

$$v = u + at \text{ and } \omega' = \omega - \alpha t$$

$$\Rightarrow \quad v = 0 + at = r(\omega - \alpha t) \quad \dots(iii)$$

$$at = r\omega - r\alpha t$$

$$\frac{r\alpha t}{2} = r\omega - r\alpha t$$

$$\Rightarrow \quad \alpha t = \frac{2}{3}\omega$$

$$v = r(\omega - \alpha t) = r\left(\omega - \frac{2}{3}\omega\right)$$

$$= \frac{r\omega}{3} = \frac{0.15 \times 5}{3} = 0.25 \text{ m/s}$$

End of Solution

Q.52 A thin-walled cylindrical pressure vessel has mean wall thickness of t and nominal radius of r . The Poisson's ratio of the wall material is $\frac{1}{3}$. When it was subjected to some internal pressure, its nominal perimeter in the cylindrical portion increased by 0.1% and the corresponding wall thickness became \bar{t} . The corresponding change in the wall thickness of the cylindrical portion, i.e. $100 \times \frac{(\bar{t} - t)}{t}$, is _____ % (round off to 3 decimal places).

Ans. (-0.06)

Given: $\epsilon_H =$ Hoop strain, $\frac{\delta D}{D} = \frac{1}{\epsilon}(\sigma_H - \mu\sigma_L)$

As $\sigma_H = \frac{Pd}{2t}$, $\sigma_L = \frac{\sigma_H}{2}$

Putting these values of stress in the hoop strain equation, we get

$$\epsilon_H = \frac{PD}{4tE}[2 - \mu] = \frac{0.1}{100} \quad \dots (i)$$

$$\epsilon_3 = \epsilon_r = \text{Radial strain} = \frac{\delta t}{t} = \frac{1}{E}[\sigma_3 - \mu(\sigma_1 + \sigma_2)]$$

$$\epsilon_r = \frac{\delta t}{t} = \frac{1}{E}[0 - \mu(\sigma_1 + \sigma_2)]$$

$$\epsilon_r = \frac{\delta t}{t} = \frac{1}{E}\left[-\mu \frac{3\sigma_1}{2}\right] = -3\mu \left[\frac{PD}{4tE}\right] \quad \dots (ii)$$

From equation (i),

$$\frac{PD}{4tE} = \frac{0.001}{2 - \mu} = \frac{0.001}{2 - \frac{1}{3}}$$

Putting the value of $\frac{PD}{4tE}$ in equation (ii)

$$\Rightarrow \frac{\delta t}{t} = -3 \times \frac{1}{3} \times \frac{0.001}{2 - \frac{1}{3}} = -0.0006$$

$$\therefore \frac{\delta t}{t} = -0.06\%$$

End of Solution

Q.53 A schematic of an epicyclic gear train is shown in the figure. The sun (gear 1) and planet (gear 2) are external, and the ring gear (gear 3) is internal. Gear 1, gear 3 and arm OP are pivoted to the ground at O . Gear 2 is carried on the arm OP via the pivot joint at P , and is in mesh with the other two gears. Gear 2 has 20 teeth and gear 3 has 80 teeth. If gear 1 is kept fixed at 0 rpm and gear 3 rotates at 900 rpm counter clockwise (ccw), the magnitude of angular velocity of arm OP is _____ rpm (in integer).

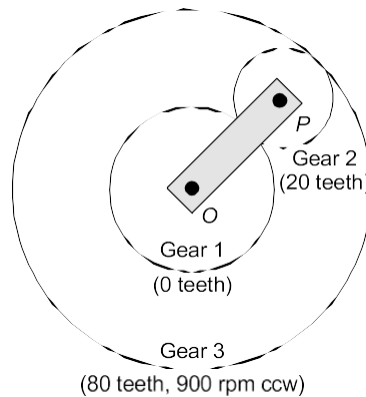

Ans. (600)

Here the sun gear is fixed and the number of teeth for following gears have been given

$$T_2 = 20$$

$$T_3 = 80$$

$$T_1 = ?$$

\therefore Here, modulus of all the gears are same, so the radius relation is given by

$$\Rightarrow r_1 + 2r_2 = r_3$$

$$\Rightarrow \frac{mT_1}{2} + \frac{2mT_2}{2} = \frac{mT_3}{2}$$

$$\Rightarrow T_1 + 2T_2 = T_3$$

$$\Rightarrow T_1 = T_3 - 2T_2 = 80 - 2 \times 20$$

$$\Rightarrow T_1 = 40 \text{ teeth}$$

Motions	Arm	1(40)	2(20)	3(80)
1 let are be fixed (w.r.t. arm) Sun speed is +x clockwise	0	+x	$-x \times \frac{40}{20}$	$-x \times \frac{40}{20} \times \frac{20}{80}$
2 Arm effect consideration	y	y+x	y-2x	$y - \frac{x}{2}$

From the data given, where sun's speed is zero.

$$\Rightarrow N_1 = 0$$

$$\Rightarrow y + x = 0 \quad \dots(i)$$

Speed of 3 is given as

$$N_3 = 900 \quad [\text{Consider counter-clockwise as positive}]$$

$$\Rightarrow y - \frac{x}{2} = 900 \quad \dots(ii)$$

Solving these two equations, we get

$$x = -600 \text{ and } y = 600 \text{ rpm}$$

So speed of arm is y which is equal to 600 rpm (counter-clockwise).

End of Solution

Q.54 Under orthogonal cutting condition, a turning operation is carried out on a metallic workpiece at a cutting speed of 4 m/s. The orthogonal rake angle of the cutting tool is 5° . The uncut chip thickness and width of cut are 0.2 mm and 3 mm, respectively. In this turning operation, the resulting friction angle and shear angle are 45° and 25° , respectively. If the dynamic yield shear strength of the workpiece material under this cutting condition is 1000 MPa, then the cutting force is _____ N (round off to one decimal place).

Ans. (2568.62)

Shear strength, $\tau_s = 1000 \text{ MPa}$

Uncut chip thickness, $t_1 = 0.2 \text{ mm}$

Width of cut, $\omega = 3 \text{ mm}$

Velocity of cutting, $V = 4 \text{ m/sec}$

Friction angle, $\beta = 45^\circ$

Shear angle, $\phi = 25^\circ$

Rake angle, $\alpha = 5^\circ$

From the Merchant's analysis

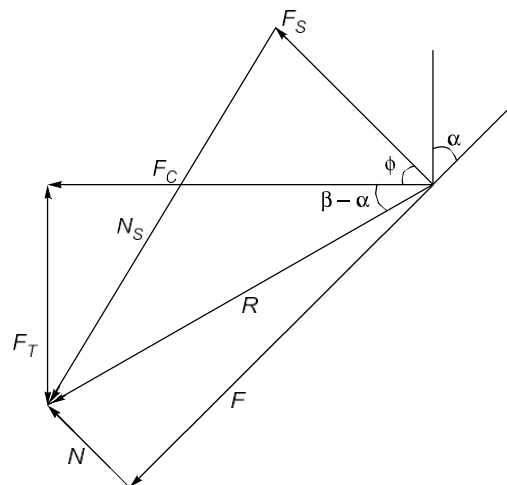

$$\Rightarrow \frac{F_C}{F_S} = \frac{R(\cos\beta - \alpha)}{R\cos(\phi + \beta - \alpha)} = \frac{(\cos\beta - \alpha)}{\cos(\phi + \beta - \alpha)}$$

$$F_C = \frac{F_S(\cos\beta - \alpha)}{\cos(\phi + \beta - \alpha)} \quad [F_S = \tau_s \times A = \tau_s \times \frac{\omega t_1}{\sin\phi}]$$

$$F_C = \tau_s \times \frac{\omega t_1}{\sin\phi} \times \frac{(\cos\beta - \alpha)}{\cos(\phi + \beta - \alpha)}$$

$$F_C = 2568.62 \text{ N}$$

End of Solution

Q.55 A 1 mm thick cylindrical tube, 100 mm in diameter, is orthogonally turned such that the entire wall thickness of the tube is cut in a single pass. The axial feed of the tool is 1 m/minute and the specific cutting energy (u) of the tube material is 6 J/mm³. Neglect contribution of feed force towards power. The power required to carry out this operation is _____ kW (round off to one decimal place).

Ans. (31.40)

Solving the question through the dimensions of the given quantities

Power = Specific energy (J/mm³) × Area of cut (mm²) × Axial feed (mm/s)

$$= 6 \text{ J/mm}^3 \times (\pi Dt) \text{ mm}^2 \times \frac{1000}{60} \text{ mm/sec}$$

$$\text{Power} = 31.40 \text{ kW}$$

End of Solution

Q.56 A 4 mm thick aluminum sheet of width $w = 100$ mm is rolled in a two-roll mill of roll diameter 200 mm each. The workpiece is lubricated with a mineral oil, which gives a coefficient of friction, $\mu = 0.1$. The flow stress (σ) of the material in MPa is $\sigma = 207 + 414 \epsilon$, where ϵ is the true strain. Assuming rolling to be a plane strain deformation process, the roll separation force (F) for maximum permissible draft (thickness reduction) is _____ kN (round off to the nearest integer).

Use :

$F = 1.15 \bar{\sigma} \left(1 + \frac{\mu L}{2\bar{h}} \right) wL$, where $\bar{\sigma}$ is average flow stress, L is roll-workpiece contact length, and \bar{h} is the average sheet thickness.

Ans. (351)

Given : $w = 100$ mm, $D = 200$ mm, $h_0 = 4$ mm, $\mu = 0.1$

$$\sigma_f = \sigma_t = 207 + 414\epsilon$$

Roll separating force, $F = ?$

$$F = 1.15 \bar{\sigma} \left(1 + \frac{\mu L}{2\bar{h}} \right) wL$$

$$\mu^2 R = (\Delta h)_{\max}$$

$$h_0 - h_f = (0.1)^2 \times 100$$

$$h_0 - h_f = 1$$

$$h_f = 3 \text{ mm}$$

$$(\Delta h)_{\max} = 4 - 3 = 1 \text{ mm}$$

$$\Rightarrow \text{Contact length, } L = \sqrt{R \Delta h}$$

$$\text{Average sheet thickness, } \bar{h} = \frac{h_0 + h_f}{2}$$

$$L = \sqrt{R \times \Delta h} = \sqrt{100 \times 1} = 10 \text{ mm}$$

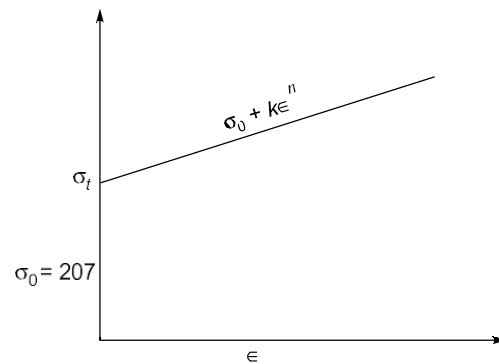

$$\bar{h} = \frac{4+3}{2} = 3.5 \text{ mm}$$

$$\sigma_f = \sigma_t = 207 + 414\epsilon$$

$$\begin{aligned} \sigma_{\text{avg}} = \bar{\sigma} &= \frac{1}{\epsilon} \int_0^{\epsilon} \sigma_t d\epsilon \\ &= \frac{1}{\epsilon} \int_0^{\epsilon} (\sigma_0 + k\epsilon^n) d\epsilon \\ &= \frac{1}{\epsilon} \left[\sigma_0 \epsilon + \frac{k\epsilon^{n+1}}{n+1} \right] \end{aligned}$$

$$\sigma_{\text{avg}} = \sigma_0 + \frac{k\epsilon}{2} \quad [\text{if } n = 1]$$

$$\sigma_{\text{avg}} = 207 + \frac{414\epsilon}{2}$$

$$\text{True strain, } \epsilon = \ln\left(\frac{h_0}{h_f}\right) = \ln\left(\frac{4}{3}\right) = 0.2876$$

$$\sigma_{\text{avg}} = \bar{\sigma} = 207 + \frac{414 \times 0.2876}{2} = 266.53 \text{ MPa}$$

$$F = 1.15\bar{\sigma} \left(1 + \frac{\mu L}{2h}\right) wL$$

$$\begin{aligned} F &= 1.15 \times 266.53 \left(1 + \frac{0.1 \times 10}{2 \times 3.5}\right) 100 \times 10 \\ &= 351 \text{ kN} \end{aligned}$$

End of Solution

Q.57 Two mild steel plates of similar thickness, in butt-joint configuration, are welded by gas tungsten arc welding process using the following welding parameters.

Welding voltage	20 V
Welding current	150 A
Welding speed	5 mm/s

A filler wire of the same mild steel material having 3 mm diameter is used in this welding process. The filler wire feed rate is selected such that the final weld bead is composed of 60% volume of filler and 40% volume of plate material. The heat required to melt the mild steel material is 10 J/mm^3 . The heat transfer factor is 0.7 and melting factor is 0.6. The feed rate of the filler wire is _____ mm/s (round off to one decimal place).

Ans. (10.71)

For welding,

$$\eta_h = \frac{H_m}{H_s} = \frac{H_m}{\frac{VI}{Av} \eta_m}$$

$$0.6 = \frac{10}{\frac{20 \times 150}{5 \times A} \times 0.7}$$

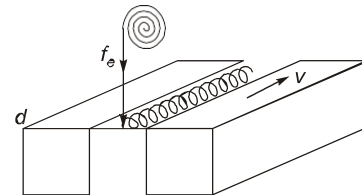

\Rightarrow Area of weld bead, $A = 25.2 \text{ mm}^2$

Volume of metal from electrode/time = Volume of metal in the joint/time

$$A_e \times f_e = A \times 0.6 \times v$$

$$\Rightarrow \frac{\pi}{4} \times (3)^2 \times f_e = 25.2 \times 0.6 \times 5$$

$$f_e = 10.71 \text{ mm/sec}$$

End of Solution

Q.58 An assignment problem is solved to minimize the total processing time of four jobs (1, 2, 3 and 4) on four different machines such that each job is processed exactly by one machine and each machine processes exactly one job. The minimum total processing time is found to be 500 minutes. Due to a change in design, the processing time of Job 4 on each machine has increased by 20 minutes. The revised minimum total processing time will be _____ minutes (in integer).

Ans. (520)

If due to design change the time of one job increases by 20 minutes, then the total minimum time would also increase by 20 minutes.

New minimum total processing time = $500 + 20 = 520$ minutes

End of Solution

Q.59 The product structure diagram shows the number of different components required at each level to produce one unit of the final product P . If there are 50 units of on-hand inventory of component A , the number of additional units of component A needed to produce 10 units of product P is _____ (in integer).

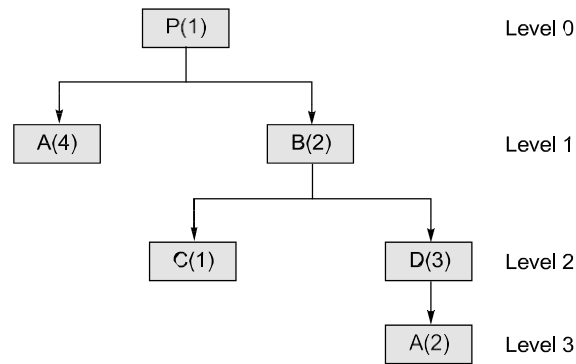

Ans. (110)

Writing the different values required for making 10 units of P .

$$\Rightarrow n(A)_{(i)} = 4 \times 10 = 40$$

$$n(B) = 20$$

$$\Rightarrow n(D) = 60$$

$$n(A)_{(ii)} = 120$$

So, the total units of A required is $40 + 120 = 160$ units

Now, we have 50 units of A in hand, therefore,

$$160 - 50 = 110 \text{ units}$$

More would be required.

End of Solution

Q.60 Consider a one-dimensional steady heat conduction process through a solid slab of thickness 0.1 m. The higher temperature side A has a surface temperature of 80°C , and the heat transfer rate per unit area to low temperature side B is 4.5 kW/m^2 . The thermal conductivity of the slab is 15 W/m.K . The rate of entropy generation per unit area during the heat transfer process is _____ $\text{W/m}^2.\text{K}$ (round off to 2 decimal places).

Ans. (1.184)

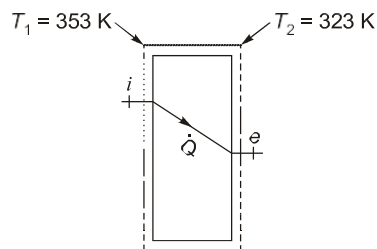

$$\dot{Q} = KA \frac{dT}{dx}$$

$$\dot{Q} = KA \frac{dT}{dx}$$

$$4500 = 15 \times 1 \times \frac{(353 - T_2)}{0.1}$$

$$30 = 353 - T_2$$

$$T_2 = 323 \text{ K}$$

$$\left(\frac{ds}{dt}\right)_{\text{C.V.}}^0 = \dot{S}_i + \dot{S}_{\text{gen}} - \dot{S}_e$$

$$\begin{aligned} \dot{S}_{\text{gen}} &= \dot{S}_e - \dot{S}_i = \frac{\dot{Q}}{T_e} - \frac{\dot{Q}}{T_i} = \frac{4500}{323} - \frac{4500}{353} \\ &= 1.184 \text{ W/k.m}^2 \end{aligned}$$

End of Solution

Q.61 In a steam power plant based on Rankine cycle, steam is initially expanded in a high-pressure turbine. The steam is then reheated in a reheater and finally expanded in a low-pressure turbine. The expansion work in the high-pressure turbine is 400 kJ/kg and in the low-pressure turbine is 850 kJ/kg, whereas the pump work is 15 kJ/kg. If the cycle efficiency is 32%, the heat rejected in the condenser is _____ kJ/kg (round off to 2 decimal places).

Ans. (2624.37)

Given data : $W_{T_1} = 400 \text{ kJ/kg}$; $W_{T_2} = 850 \text{ kJ/kg}$; $W_P = 15 \text{ kJ/kg}$; $\eta = 0.32$

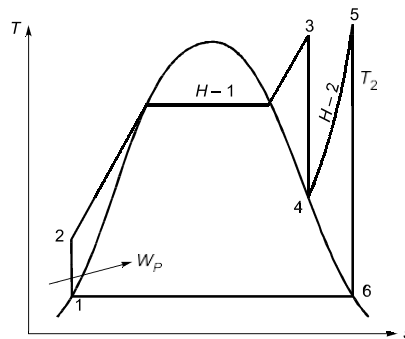

∴ Efficiency of the cycle will be given as

$$\eta = \frac{W_{\text{net}}}{Q_s} = \frac{W_{T_1} + W_{T_2} - W_P}{Q_s}$$

$$\Rightarrow 0.32 = \frac{400 + 850 - 15}{Q_s}$$

$$\Rightarrow Q_s = 3859.37 \text{ kJ/kg}$$

∴ Efficiency can also be written as

$$\eta = 1 - \frac{Q_{\text{Rej}}}{Q_s}$$

$$\Rightarrow 0.32 = 1 - \frac{Q_{\text{Rej}}}{3859.37}$$

$$\Rightarrow Q_{\text{Rej}} = 2624.37 \text{ kJ/kg}$$

End of Solution

Q.62 An engine running on an air standard Otto cycle has a displacement volume 250 cm^3 and a clearance volume 35.7 cm^3 . The pressure and temperature at the beginning of the compression process are 100 kPa and 300 K , respectively. Heat transfer during constant-volume heat addition process is 800 kJ/kg . The specific heat at constant volume is 0.718 kJ/kg.K and the ratio of specific heats at constant pressure and constant volume is 1.4 . Assume the specific heats to remain constant during the cycle. The maximum pressure in the cycle is _____ kPa (round off to the nearest integer).

Ans. (4809.136)

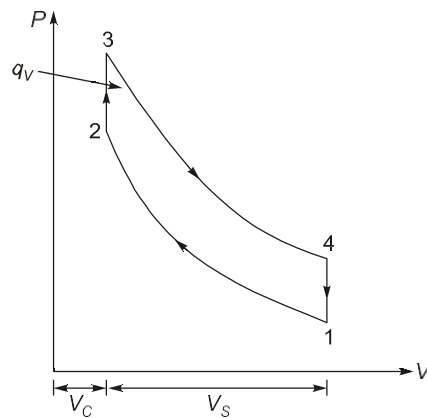

$$\frac{T_2}{T_1} = \left(\frac{P_2}{P_1}\right)^{\frac{\gamma-1}{\gamma}} = \left(\frac{V_1}{V_2}\right)^{\gamma-1} = (r)^{\gamma-1}$$

$$r = \frac{V_1}{V_2} = \frac{V_c + V_s}{V_c} = 1 + \frac{V_s}{V_c} = 1 + \frac{250}{35.7}$$

$$r = 8$$

$$\frac{T_2}{300} = (8)^{1.4-1}$$

$$T_2 = 689.22 \text{ K}$$

$$q_v = C_v(T_3 - T_2)$$

$$800 = 0.718(T_3 - 689.22)$$

$$T_3 = 1803.426 \text{ K}$$

Also,

$$\left(\frac{P_2}{P_1}\right)^{\frac{\gamma-1}{\gamma}} = (r)^{\gamma-1}$$

$$\frac{P_2}{P_1} = (r)^\gamma$$

$$\frac{P_2}{100} = 8^{1.4}$$

$$P_2 = 1837.92 \text{ kPa}$$

$$P_3 = P_{\max}$$

$$PV = mRT$$

$$P \propto T$$

$$\frac{P_2}{P_3} = \frac{T_2}{T_3}$$

$$\frac{1837.92 \text{ kPa}}{P_3} = \frac{689.22 \text{ K}}{1803.426 \text{ K}}$$

$$P_3 = 4809.136 \text{ kPa}$$

End of Solution

Q.63 A steady two-dimensional flow field is specified by the stream function

$$\psi = kx^3y,$$

where x and y are in meter and the constant $k = 1 \text{ m}^{-2}\text{s}^{-1}$. The magnitude of acceleration at a point $(x, y) = (1 \text{ m}, 1 \text{ m})$ is _____ m/s^2 (round off to 2 decimal places).

Ans. (4.242)

$$\psi = x^3y$$

$$U = \frac{\partial \psi}{\partial y}$$

$$U = x^3$$

$$a_x = U \frac{\partial U}{\partial x} + V \frac{\partial U}{\partial y}$$

$$a_x = x^3(3x^2)$$

$$a_x = 3$$

$$V = \frac{-\partial \psi}{\partial x}$$

$$V = -3x^2y$$

$$a_y = U \frac{\partial V}{\partial x} + V \frac{\partial V}{\partial y}$$

$$= x^3(6xy) + (-3x^2y)(-3x^2)$$

$$a_y = (-6) + (9) = 3$$

$$|a| = \sqrt{3^2 + 3^2} = 3\sqrt{2} = 4.242$$

End of Solution

Q.64 Consider a solid slab (thermal conductivity, $k = 10 \text{ W}\cdot\text{m}^{-1}\text{K}^{-1}$) with thickness 0.2 m and of infinite extent in the other two directions as shown in the figure. Surface 2, at 300 K , is exposed to a fluid flow at a free stream temperature (T_∞) of 293 K , with a convective heat transfer coefficient (h) of $100 \text{ W}\cdot\text{m}^{-2}\text{K}^{-1}$. Surface 2 is opaque, diffuse and gray with an emissivity (ϵ) of 0.5 and exchanges heat by radiation with very large surroundings at 0 K . Radiative heat transfer inside the solid slab is neglected. The Stefan-Boltzmann constant is $5.67 \times 10^{-8} \text{ W}\cdot\text{m}^{-2}\text{K}^{-4}$. The temperature T_1 of Surface 1 of the slab, under steady-state conditions, is _____ K (round off to the nearest integer).

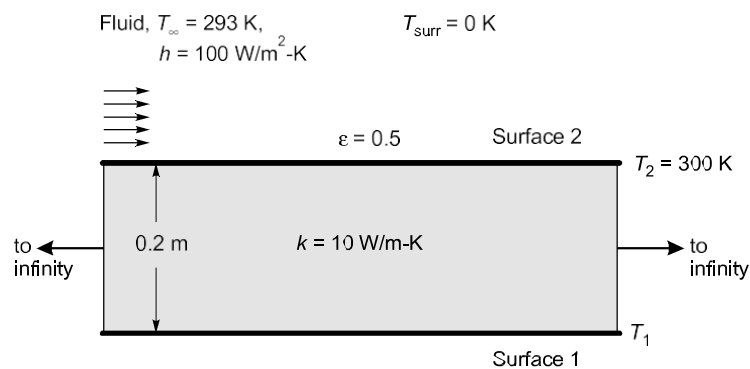

Ans. (319)

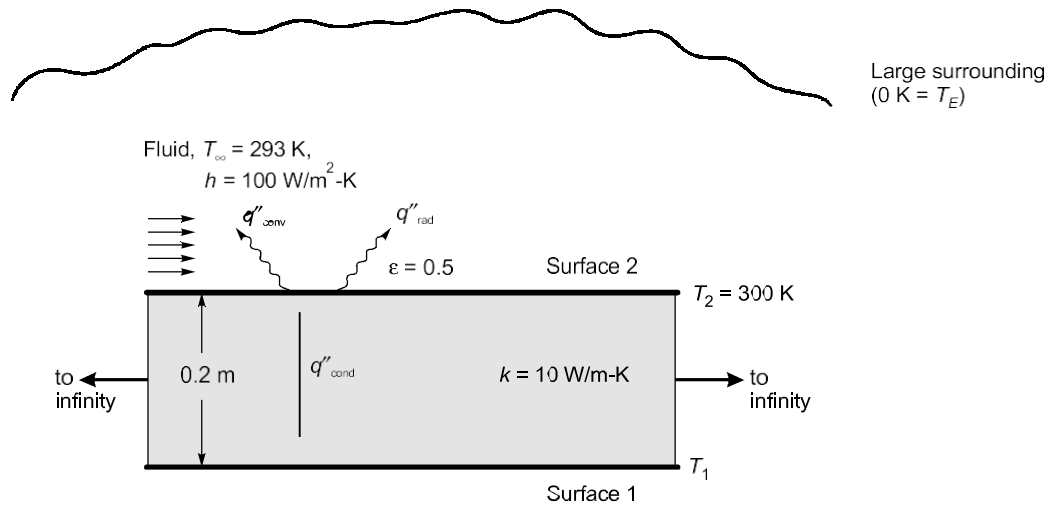

Applying energy balance on surface (2)

$$q''_{\text{cond}} = q''_{\text{conv}} + q''_{\text{rad}}$$

$$\frac{K(T_1 - T_2)}{L} = h(T_2 - T_\infty) + \sigma \epsilon (T_2^4 - T_E^4)$$

$$\frac{10 \times (T_1 - 300)}{0.2} = 100 \times (300 - 293) + 0.5 \times 5.67 \times 10^{-8} \times (300^4 - 0^4)$$

$$T_1 = 318.59 \text{ K}$$

$$T_1 = 319 \text{ K}$$

End of Solution

Q.65 During open-heart surgery, a patient's blood is cooled down to 25°C from 37°C using a concentric tube counter-flow heat exchanger. Water enters the heat exchanger at 4°C and leaves at 18°C. Blood flow rate during the surgery is 5 L/minute.

Use the following fluid properties:

Fluid	Density (kg/m ³)	Specific heat (J/kg-K)
Blood	1050	3740
Water	1000	4200

Effectiveness of the heat exchanger is (round off to 2 decimal places).

Ans. (0.42)

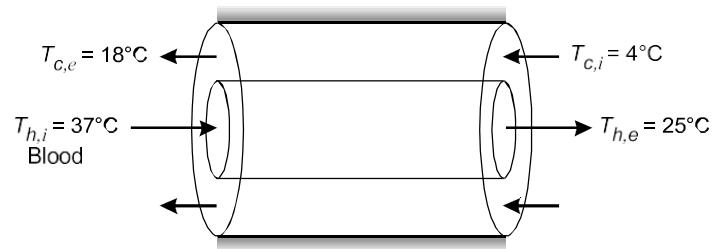

Applying energy balance

$$C_h(T_{h,i} - T_{h,e}) = C_c(T_{c,e} - T_{c,i})$$

$$C_h(37 - 25) = C_c(18 - 4)$$

$$C_h \times 12 = C_c \times 14$$

$$C_h = C_{\max}; C_c = C_{\min}$$

$$\epsilon = \frac{C_c(T_{c,e} - T_{c,i})}{C_{\min}(T_{h,i} - T_{c,i})} = \frac{T_{c,e} - T_{c,i}}{T_{h,i} - T_{c,i}}$$

$$\epsilon = \frac{18 - 4}{37 - 4} = \frac{14}{33} = 0.4242$$

$$\epsilon = 0.42$$

End of Solution

